

## HB-DAC1704 Board Version 1.01

### 1. Introduction

Why a new DAC design? There are some good reasons for designing this new DAC:

**Jitter:** It is well known that jitter reduces the sound quality. Jitter can be generated everywhere, but there are some major jitter sources you can find when looking at the audio chain: the first source is the CD player itself. You can buy a better one with good mechanics, but the electronics of the player adds some jitter, too. Normally, digital audio will then be transported via the SPDIF, AES/EBU or USB to the digital receiver. These standards are defined to contain data and clock on one wire (differential or coaxial) and the receiver has the job to split the clock from the data. Also the best chips add a lot of jitter by doing this. Less than about 200ps additional jitter is not possible. The only way to overcome this problem is to resynchronize the incoming clock with a clean jitter free synchronous clock.

There are several possibilities to generate a synchronous clock. You could take a quite complex PLL design. Complex because a PLL normally add a lot of jitter like the PLL in the digital receiver does for clock recovery. You could add a VCXO (voltage controlled crystal oscillator) but this would increase costs and complexity and then you have the problem to be fixed on one sample rate. Another method is to take a sample rate converter (SRC) with a fixed output frequency which is generated by a low jitter oscillator. The input frequency is variable. This means the sample rate is variable (here from 44.1 kHz to 192 kHz) which is a big advantage. This concept reduces the jitter nearly to the jitter of the oscillator plus the jitter of the output stage of the SRC. If you add a resynchronisation after the SRC you could improve the jitter once again. Here this is done by Flip Flops which are clocked with the crystal oscillator.

**Digital filtering:** For easy analogue filtering normally an 8 times oversampling filter is used. But these filters add pre- and post ringing to signal. The sound is not so precise and clear. It is slushier. In the HB-DAC1704 no traditional oversampling filters are used. The upsampling method is done by a very precise interpolation in the SRC and no downsampling filtering is needed when using the direct downsampling feature of the new high end chip (SRC4392) from Texas Instruments. To verify the difference between an SRC as "oversampling filter" and a direct audio chain without any digital filtering the design includes a mode called NON oversampling mode. Here the clock is taken from the digital receiver to clock the DACs directly.

**DAC:** Here the very best R2R DAC is used (PCM1704). The advantage of a R2R DAC versus the sigma delta DAC is a much better resolution of small signals. And this is the most important issue with audio: to have excellent music quality when the music is more silent and more complex instead of loud where the ears distortion is growing and effects like sound masking occurs. In the HB-DAC1704 two DACs per channel are used to reduce noise and THD. They can work in parallel or in balanced mode. The balanced mode gives a better noise immunity (common mode rejection).

**USB** is a special feature which is optionally designed in. Because of the design structure (reclocking and SRC) additional jitter will not be generated when connecting the DAC directly to a PC. Noise coupling from the PC to the DAC board is cancelled out by totally isolating the USB receiver from the DAC board via fast optocouplers.

In total these advantages create a very precise and clear sound.

Other features included are an AES/EBU balanced input isolated with a transformer and selectable ground connection, two further SPDIF inputs with selectable ground connection and one SPDIF output which is driven from the selected input.

The intention of missing I/V/ converter/post analogue filtering is that everybody can build up his own I/V converter and analogue filters with his own goals of realizing ultimate audio quality. A very low noise power supply/regulator delivering +/-5V at 200mA is needed for the HB-DAC1704. It should have low noise in the lower frequency range (<1kHz). Borbely Audio offers very high quality I/V converters/filters and power supplies/regulators. The discrete JFET amplifiers offer very high resolution also with small amplitudes the DACs have.

## 2. Block Diagram

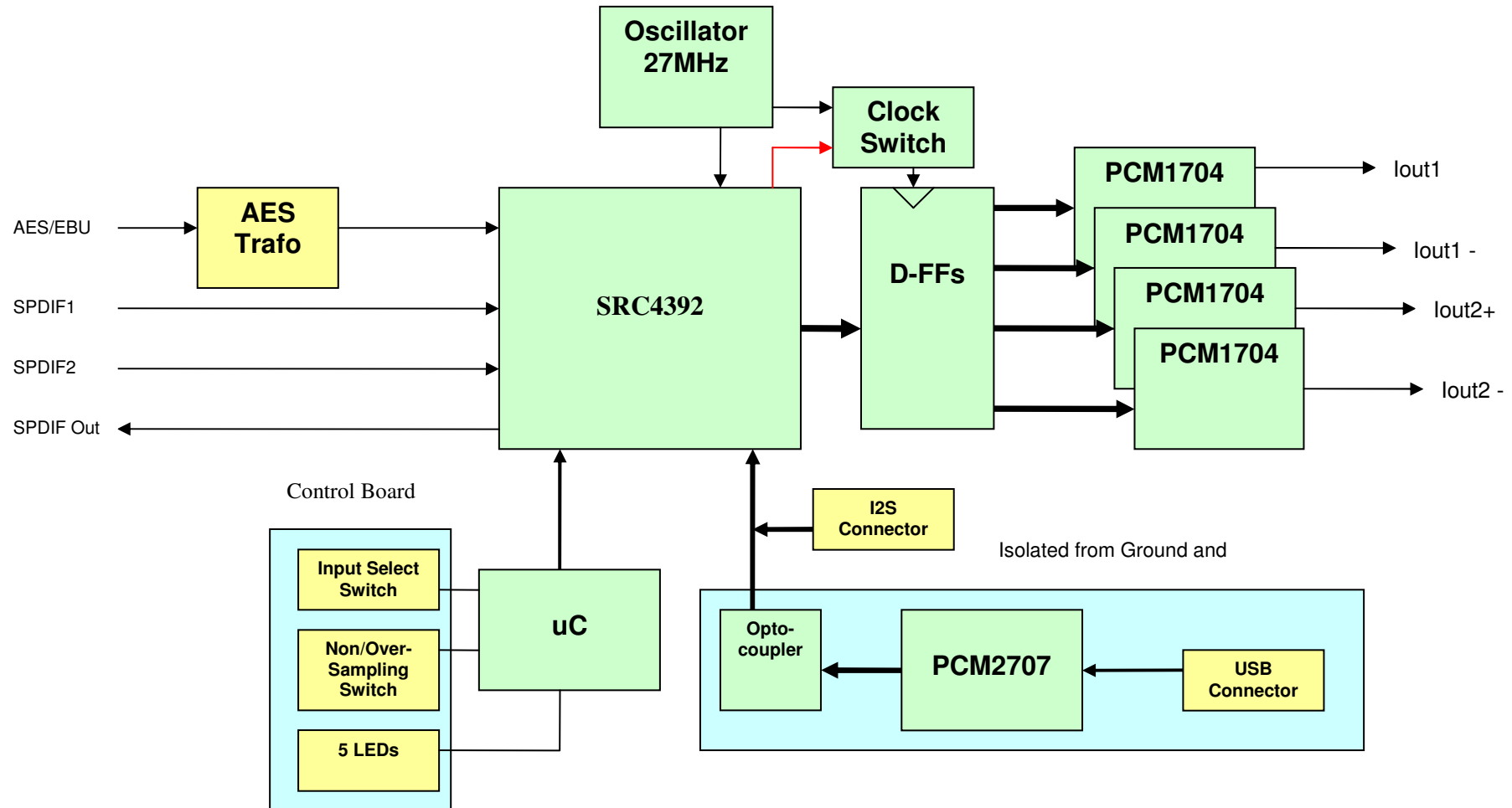

### 3. How to connect to the board

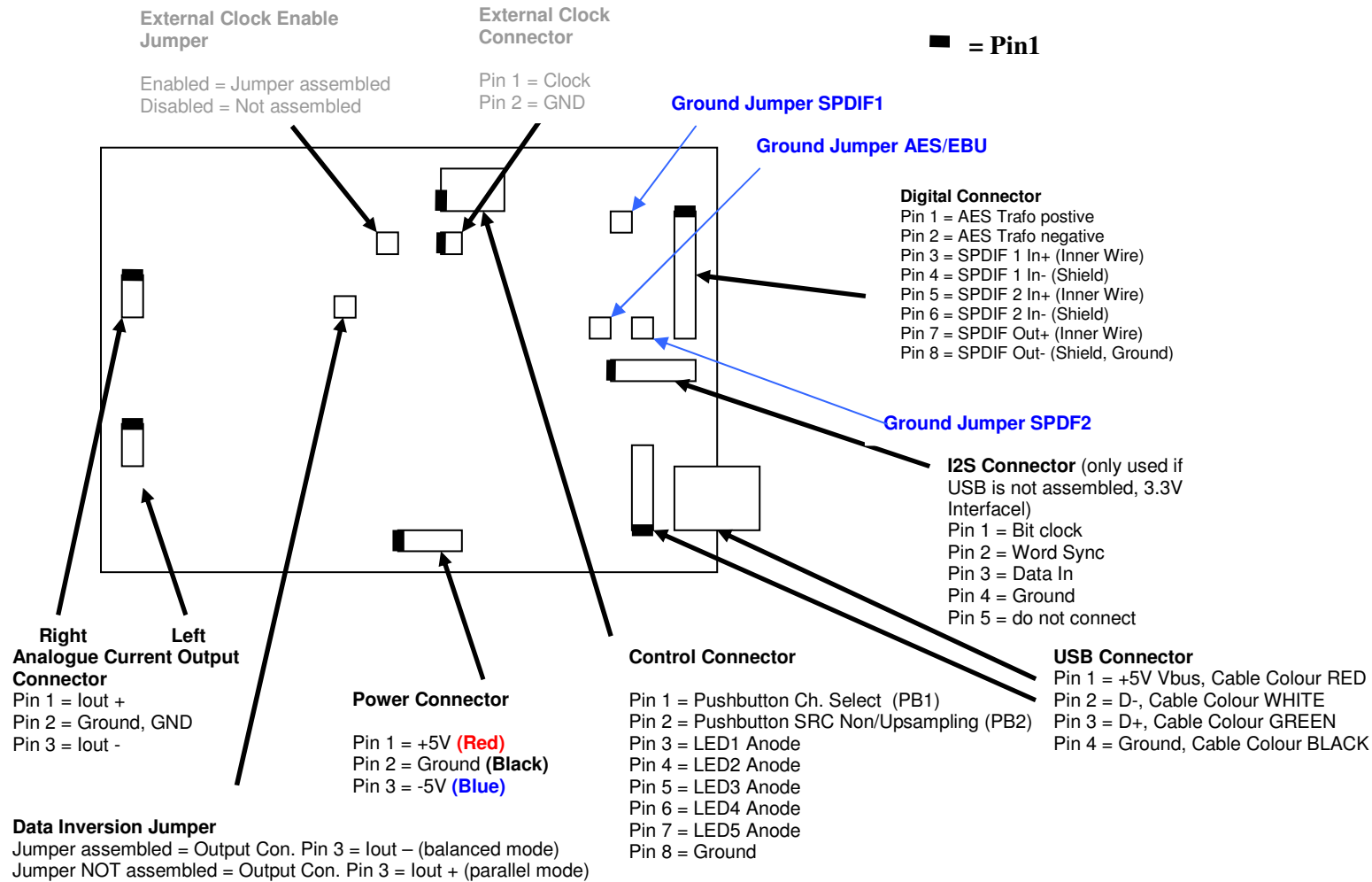

### 3.1 Power

The board is delivered with a power connector with coloured cables. **Connect RED to +5V, BLUE to -5V and BLACK to Ground.** The board will be destroyed if you connect it wrong. (It is not possible to plug in the connector the wrong way). Be sure that the voltages are in the specified range (+/-5V, +/-5%). No guarantee for reversed power connections!

### 3.2 AES/EBU and SPDIF Inputs

The digital audio receiver offers balanced inputs RX+ and RX-. For SPDIF input the RX- inputs must be grounded. This can be done on board by assembling [Ground Jumper SPDIF 1/2](#) (default setting). But user can also decide to ground the SPDIF's inputs e.g. at the connector. Then the [Ground Jumper SPDIF 1/2](#) should be not assembled. Figure 3 shows the simplified input schematic for SPDIF. All SPDIF inputs are terminated with 75 Ohm.

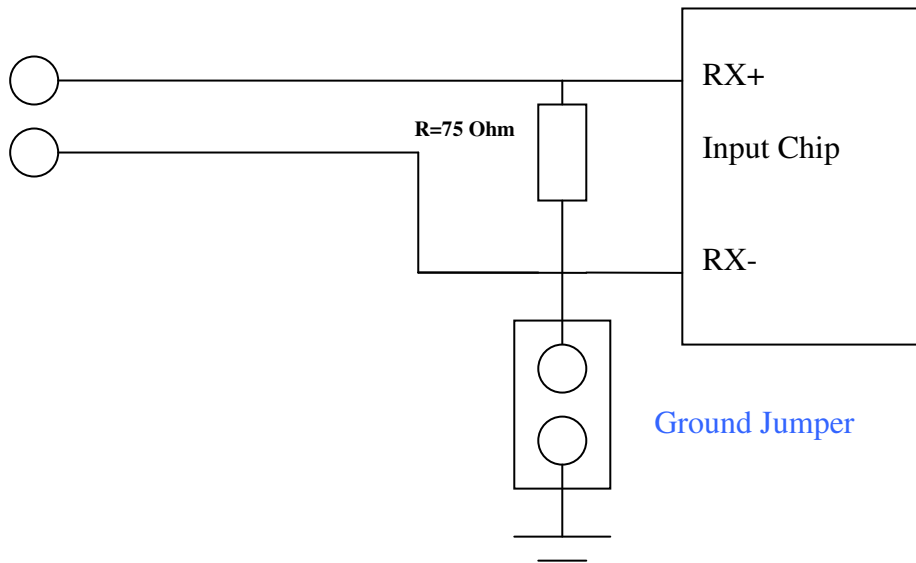

The AES/EBU input has a signal isolation transformer. After the transformer the user has the possibility for grounding the RX- Input. Then the [Ground Jumper AES/EBU](#) should be assembled (default is not assembled). Figure 4 shows the simplified input schematic for AES/EBU. The AES/EBU input is terminated with 110 Ohm.

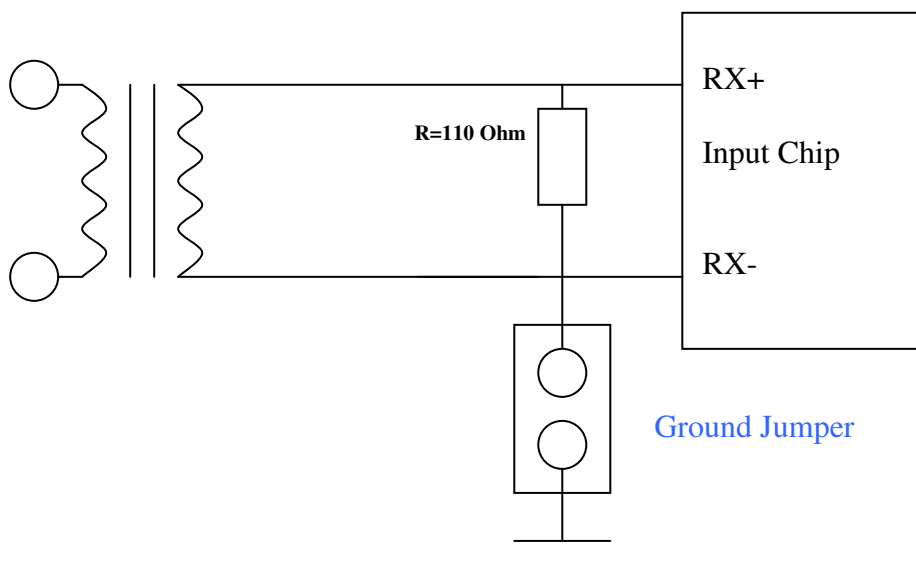

### 3.2 SPDIF Output

The SPDIF output is driven from the selected input channel and includes a serial termination resistor of 75 Ohm. This signal is ground based.

### 3.3 I<sup>2</sup>S Input

If the USB option is not assembled user can use the I<sup>2</sup>S input connector as a digital input.

### 3.4 USB Input

When the USB option is supported user has two ways for connecting to USB:

3.4.1 Simply plug in the USB cable which is connected to the PC. The USB part of the board is powered by the PC itself. After connecting the USB cable the PC automatically looks for a driver (generic audio HID driver). Then the user can handle the board like a USB sound card.

3.4.2 The second connector is a standard computer connector for internal extension cables. Sometimes it is more convenient to have the USB connector farther away. Then you are able to plug the extension cable to that 4 pin connector.

### 3.5 Analogue Out

User can choose between balanced current output or parallel output of the two DAC chips per channel. With **Data Inversion Jumper** assembled both channels are in balanced mode. Pin 3 of the connectors are inverted (I out -). Without jumper the two DAC chips are working in parallel, i.e. the current outputs are in-phase. Connect Pin 1 and Pin 3 together.

### 3.6 Control Interface and Control board

To control the DAC board user can connect the small control board (standard accessory) to the control connector. This board includes two pushbuttons and 5 LEDs. See chapter 4 for function description. If user like his own stile of push buttons and LEDs it should be noted that one pin of the pushbutton must be connected to pin 1, 2 of the control connector and the second pins of the pushbutton with ground (pin 8). The anodes of the LEDs must be connected to the connector pins, the cathodes to ground.

### 3.6.1 Control Board

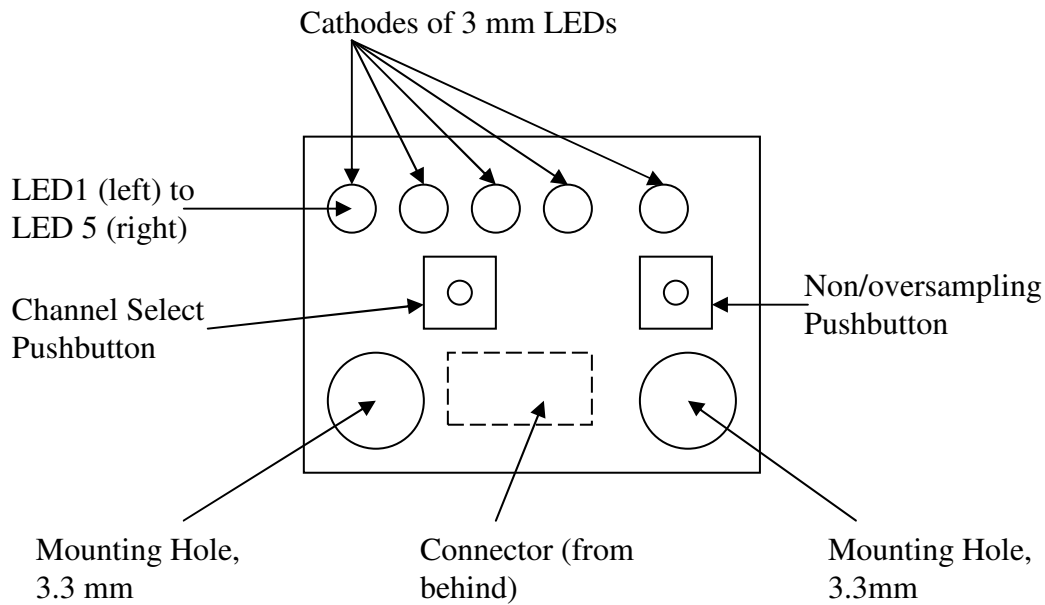

### 3.7 External Clock Input

User can use his own external clock. It can be connected to the **External Clock Connector**. The internal oscillator must then be disabled. This can be done by assembling the **External Clock Enable Jumper** (default not assembled, internal oscillator enabled). The external clock input function only in normal mode with SRC.

## 4. Functional Description

Most of the functionality is explained in the introduction and can be studied in the block diagram. Note that the microcontroller (uC) is normally in total power down mode. No asynchronous clock from the uC disturbs the signals. Also the very noisy PC surrounding is totally isolated in ground and power. The DACs power supply is decoupled with low ESR ceramic capacitors with more than double the specified value in the datasheet. The critical oscillator has its own power supply (low noise LDO) to reduce its jitter.

If the user has chosen the USB option, the I<sup>2</sup>S connector can not be used.

### 4.1 Non “oversampling” Mode

It is possible to change the clock system by software for individual listening purposes and verifying the “oversampling” idea with the sample rate converter (SRC). Therefore a pushbutton was included (see 4.2.1). If user switches to the non oversampling mode the digital receiver output is fed directly to the DACs. The digital receiver only needs a reference clock, which is provided by the crystal oscillator and reconstructs the clock (the red clock path in the block diagram) from the digital audio data. This clock is then fed to the flip flops to pass the data to the DACs. Note that this mode increases the jitter because the resynchronisation in front of the DACs does not work anymore: the recovered clock has more jitter included (as discussed before) than a crystal oscillator. Also note that analogue filtering is quite difficult in this mode (to get a good suppression until  $f_s$ ) and aliasing effects could occur. But user can verify both modes by pressing a pushbutton.

### 4.2 uC Functionality

The main function of the uC is to initialize the SRC4392, to select the different inputs and to display the selected functions.

#### 4.2.1 Function Select

With two pushbuttons the user can select:

- Channel Select (PB1). Every push on the button changes the input channel. The default (PB1 not pressed) is the AES/EBU channel, followed by SPDIF 1, SPDIF2 and USB/I<sup>2</sup>S. Then it starts with the AES/EBU channel again.
- Non/Oversampling mode. Every push on the button toggles between non oversampling and “oversampling” mode.

#### 4.2.2. LED Indication

Five LEDs indicate the board status.

LED1 on: AES/EBU channel selected  
LED2 on: SPDIF 1 channel selected  
LED3 on: SPDIF 2 channel selected  
LED4 on: USB/I<sup>2</sup>S channel selected  
LED5 on: Non oversampling mode selected, LED5 off: normal mode via SRC

### 5. Specifications for HB-DAC1704 Board Version 1.01

- PCB: Version V1.01, 2 Layer,  
Dimensions: 56.3 mm x 80.55 mm
- Supply voltage(s): +/-5V +/-5% regulated, low noise supply required
- Supply current: 170mA for +5V, 130mA for -5V
- Inputs: 1 x AES/EBU input, 110 Ohm isolated with signal transformer,  
2 x SPDIF input, 75 Ohm  
1 x I<sup>2</sup>S input (header) or 1 x USB input (USB 1.1, optional, no USB driver needed, HID device)
- Output digital : 1 x SPDIF Output, 75 Ohm (driven from selected input), 2.7V
- Outputs analogue: 4 x Current outputs, max. 1.2 mA/output, Stereo, each Channel with 2 DACs in parallel or in balanced mode  
Selectable with Jumpers
- Control Interface:  
LED current to ground: 15mA typ., 18mA max. , short circuit protected
- Input Sample Rate: 4 kHz to 210.9 kHz
- DAC Sample Clock: 210.9kHz, or input clock rate w/o sample rate converter (selectable)
- System Clock: 27MHz, Period Jitter < 13ps
- Micro Controller: always in total power down, except by channel selection or during init
- THD: PCM1704UK: 0.0005% (-105dB). Measured with 2 x 100 Ohm passive I/V-Converter
- Noise: Depends on the noise of the power supply (>100dB, typ.)

**6.1. Mechanical Dimensions of HB-DAC1704 Control Board Version 1.01**

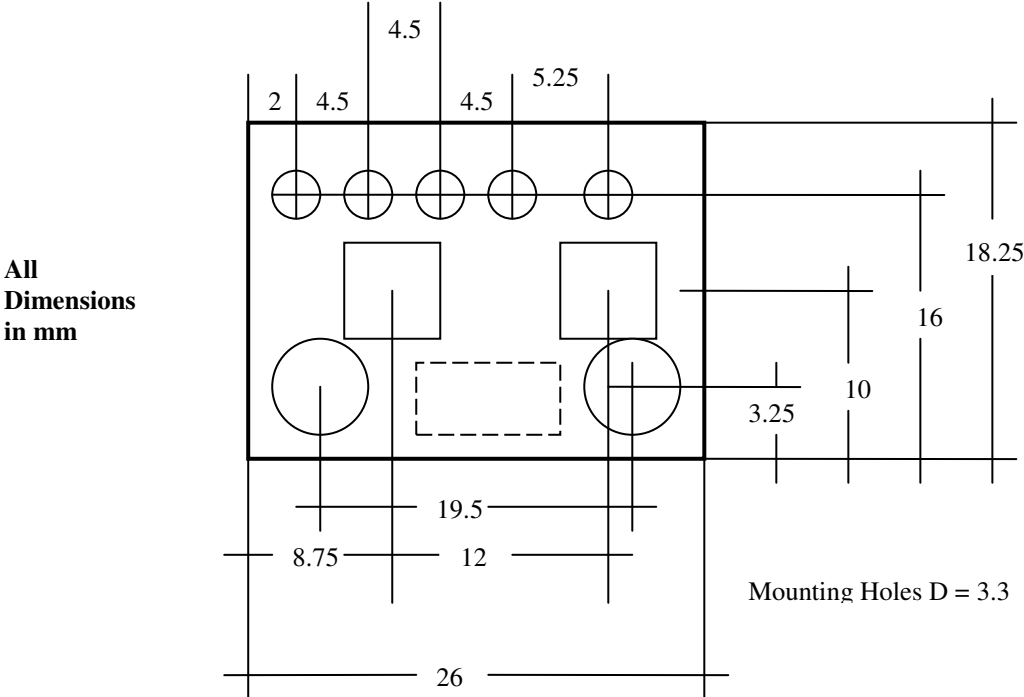

**6.2. Mechanical Dimensions of HB-DAC1704 DAC Board Version 1.01**

