

ALL-FET I/V CONVERTER. EB-109/437/VER1

The EB-109/437/VER1 is an ALL-FET Class-A I/V converter with exceptional resolution, and dynamics. Its natural and transparent sound makes it equally applicable in high-end home systems as in studio monitor and recording applications. The EB-109/437/VER1 outperforms most high-end I/V converters on the market in terms of sonic quality, irrespective of price.

The EB-109/437 I/V converter can be used with most current and voltage output DACs, like the PCM1704, PCM1794, AD1955, ES9018, the Wolfson WM8740 and many others.

Only FETs (JFETs and MOSFETs) are used as active elements in the amplifier. The resistors are all high quality Vishay-Dale and Caddock. All electrolytic caps are Nichicon FINE GOLD MUSE/KZ, ELNA CERAFINE/SILMIC II and the compensation caps are MICA or polystyrene.

Two amplifiers are laid out on one board (the size is 110x145mm), but they can be used independently. This facilitates testing and trouble-shooting. Two of the 437 boards are needed to provide fully balanced operation, see the application notes.

Circuit description.

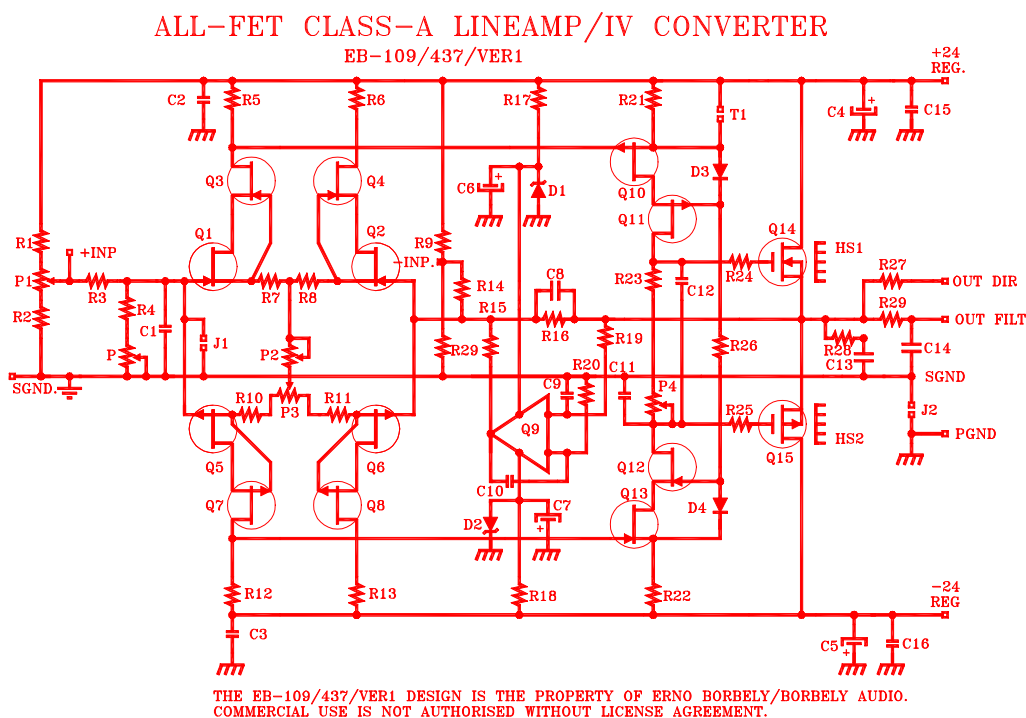

Fig. 1.

The schematic of the ALL-FET 437 is shown in fig. 1. The complementary differential input consists of very closely matched single JFETs: Q1 and Q2 are 2xK170BL and the Q5, Q6 are 2xJ74BL respectively. They are cascoded with Q3/Q4 and Q7/Q8. The second stage, consisting of JFETs Q10 and Q13, are also cascoded for good linearity and low capacitance modulation. Blue LEDs D3 and D4 provide the necessary bias for the cascode JFETs Q11 and Q12. The output devices: Q14/Q15 are TO-220 MOSFETs. They are operating in Class-A at approx. 70mA; proper heat sinking is therefore mandatory.

Q9 is a JFET-input servo amplifier, providing tracking of the output offset to less than 1mV. The RC-networks of R19-C9 and R20-C10 filter out all AC signals over 1 Hz. The servo is therefore only operational at less than 1 Hz, and should not affect the sound of the amplifier. Nevertheless, if you feel

that it does, don't hesitate to try different opamps for this. D1 and D2 are IC shunt regulators, supplying Q9 with ± 10 Volt.

The amplifier is using the best components available today. The resistors are Vishay-Dale except for the input and feedback resistors, which are Caddock. The layout it made for 0.5" (12.5mm) spacing and, most places also for 0.2" (5mm) spacing. I.e. you can use Caddock resistors almost everywhere, if you wish. Be careful when inserting the Caddocks, do not bend the leads; they fit in the 0.2" spaced layout. The frequency compensating capacitors are polystyrene or Mica caps, the electrolytics C4, and C5 are Nichicon FIND GOLD MUSE, Nichicon KZ, ELNA CERAFINE or ELNA SILMIC II.

The open loop linearity of the amplifier is exceptionally good; O.L. THD is $<0.05\%$ at 1kHz, 3VRMS. This is reduced to below the measurement limit of the HP 339A distortion analyzer when feedback is applied with resistors R16-R14. The rise time of the amplifier is about 200 nanoseconds for an output of +10V and the closed loop frequency response is close to 1 MHz! Output impedance is less than 1 Ohm, so resistor R27/R29 determine the actual output impedance seen by the outside world. R29/C14 can be used as a 6dB/octave low-pass filter. For a 150kHz filter R29=681R and C14=1.5nF. Note that the output impedance at the OUT FILT is then equal R29!

The closed loop gain can be reduced by changing the value of R14, however, at very low gain the compensation cap C11 has to be changed as well. These are the necessary changes for lower gain settings:

- 16dB: R14=1k82 (No other change)
- 12dB: R14=3k32 (No other change)
- 6dB: R14=10k, C11=330pF

NOTE: the 437 is Not Unity Gain Stable (NUGS), so it should not be considered for unity gain buffer operation.

How to hook up your DAC to the 437.

The 437 can be used in a number of IV converter configurations, both in balanced passive and in balanced active mode. Fig. 2 shows the balanced passive conversion with unbalanced audio output. This can be used for all types of DAC boards mentioned above. The advantage of this configuration is that it automatically cancels out the DC offset from single-supply DACs like the PCM1794 or the ES9018 on the Buffalo II.

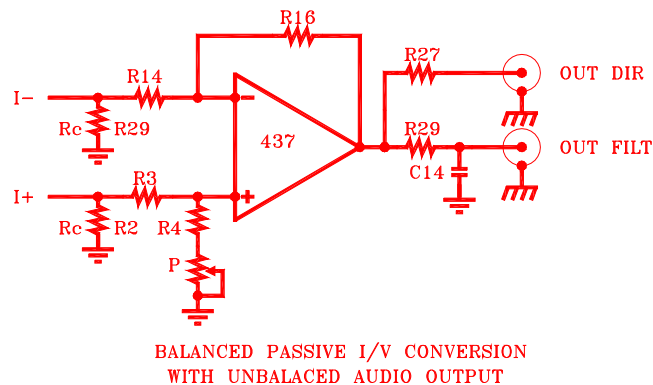

Fig. 2. Balanced passive IV conversion with unbalanced audio output.

The conversion is done with resistors R2 and R29 at the +INP and the -INP respectively. Normally these resistors cannot be chosen arbitrarily, because of the protection diodes at the current outputs (PCM1704), or the available supply voltage for the DAC chip on the Buffalo II board (ES9018). Please consult the appropriate DAC datasheet. Typically R2/R29 is 50-150 Ohm for the PCM types and 10R for the ES9018, which will produce a voltage of $I \times R2$ at the +INP and $I \times R29$ at the -INP. The 437 converter is used as a balanced-to-unbalanced converter with gain. The R16/R14 ratio has to be selected to provide the necessary gain. Table 1 shows the components values for 2VRMS output, using the 437 with balanced passive conversion as shown in fig. 3.

	PCM1704 single 2 chips	PCM1704 balanced, 4 chips	PCM1794 RAKK DAC III	ES9018 Buffalo II board
OUTPUT current	2.4mA p-p	2.4mA p-p	7.8mA p-p	16mA p-p
R2, R29	150R	75R	47R5	10R
R3, R14	R14:1k, R3 open	1k	1k2	1k1
R4, R16 P shorted	R16: 16k2 R4 shorted	16k2	10k	22k
Audio output across I/V resistor	120mV	60mV	130mV	50mV

Table 1. Component values for 2VRMS output, using the 437 with balanced passive IV conversion, see Fig. 3.

Two of the circuits shown in fig. 2 can be used for balanced passive conversion with balanced audio output, see fig. 3. Again, this configuration can be used for all types of current DACs.

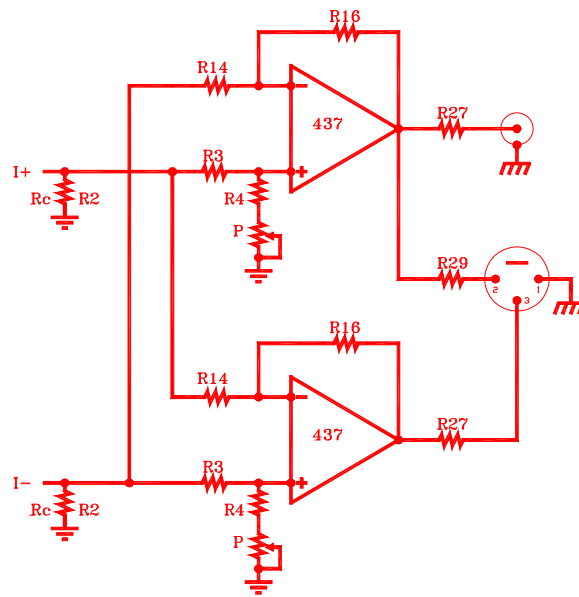

BALANCED PASSIVE I/V CONVERSION
WITH BALANCED AUDIO OUTPUT

Fig. 3. Balanced passive conversion with balanced audio output

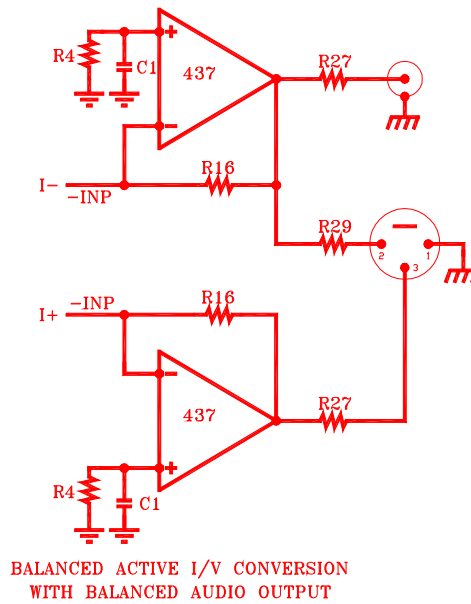

Fig. 4. Balanced active conversion with balanced audio output.

Balanced active conversion is shown in fig. 4. For current output DACs the output from the DAC is connected to the $-INP$ of the converter, with R14 shorted. The feedback resistor R16 determines the conversion factor, i.e. the V_{out}/I_{in} ratio. If the DAC current is $\pm 1.2\text{mA}$ like with the PCM1704, and you select $R16=2\text{k}\Omega$, then the maximum output voltage will be $V_{out}=I_{in} \times R16=5.7\text{V}$ peak-to-peak or 2V RMS at the unbalanced output and twice that at the XLR output. For balanced PCM1704 with 4 DAC chips or paralleled PCM1704 R16 should be $1\text{k}\Omega$.

Note that the unbalanced output is generated from the I- only. Should a high CMRR unbalanced output be needed then it has to be made from both outputs using a balanced-to-unbalanced converter, see fig. 5. Also, if this configuration is used for the single supply PCM1794 or the ES9018 type DAC, then the output DC will not be zero. To cancel out the DC offset a balanced-to-unbalanced converter has to be used. Any of the Super Buffers (SB, SB1, SB2) are applicable for this task, see the manuals on the homepage.

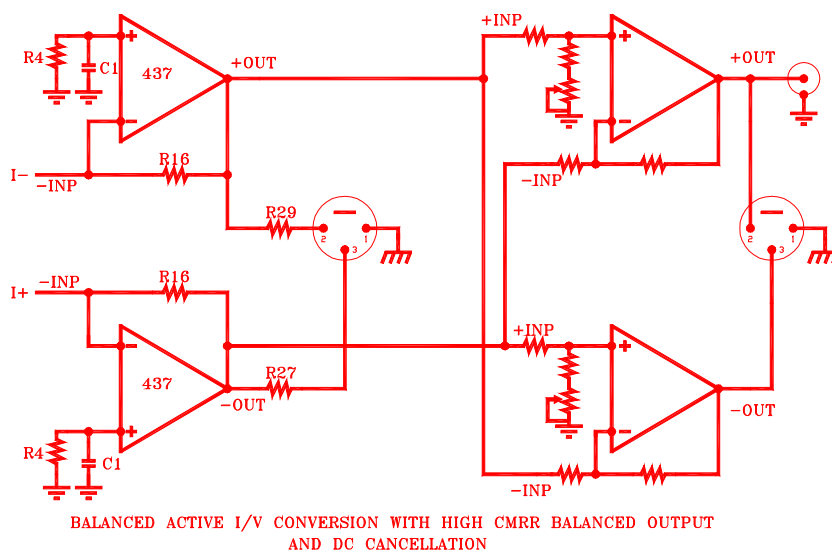

Fig. 5. Balanced active conversion with high CMRR balanced output and DC cancellation.

REGULATORS.

Recommended regulator for the 437 is the dual low-noise super-shunt: EB-906/255 regulators see fig. 6. These can supply up to 200mA current each, so theoretically each can supply two amps in balanced operation. However, for the highest sound quality we recommend to use a separate +/-regulator for each amplifier, meaning four regulators for a fully balanced I/V converter.

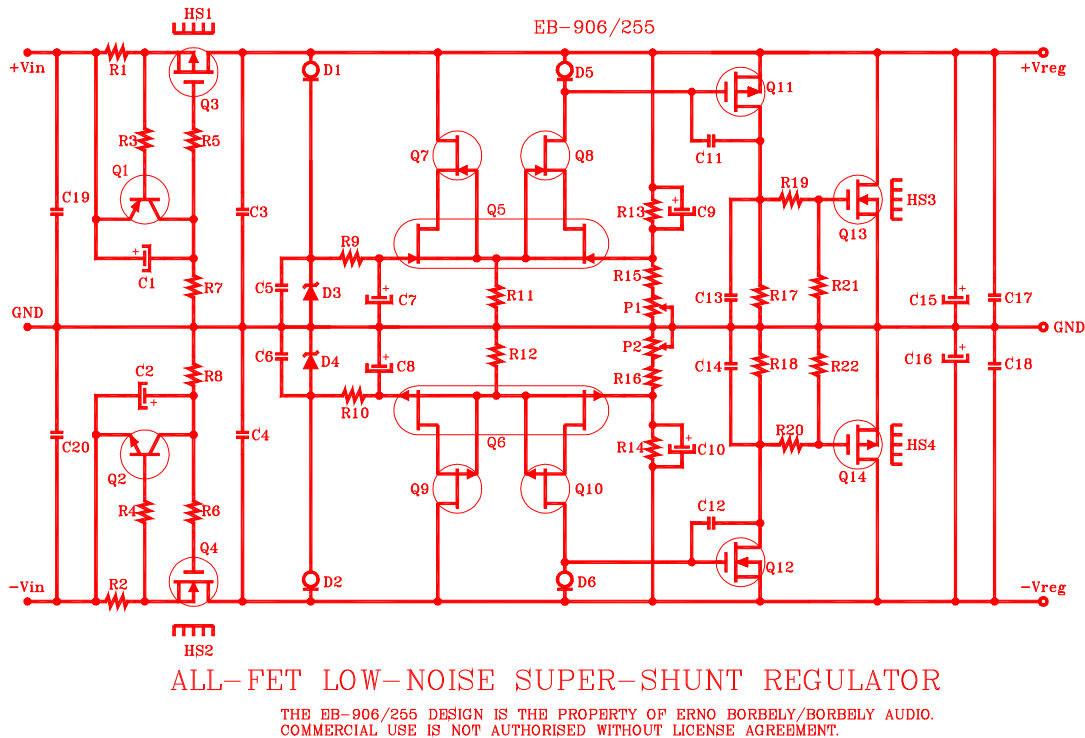

Fig. 6. The EB-906/255 ALL-FET, Low-noise Super-Shunt regulator.

For the description of the EB-906/255 super-shunt regulator please see the manual on the homepage.

437 Assembly.

Use 2% silver bearing solder if available. Start the assembly with the jumpers, resistors/trimpots, and then mount the capacitors. Install all small signal JFETs. Note the orientation of the capacitors and the FETs very carefully! Install the output MOSFETs on the heatsinks with the insulators provided and then install them on the PCB. Do not install Q9 yet. Test both amplifiers separately; see Setup procedure.

Setup Procedure.

Test each amplifier module separately, before you install the PCB in the chassis. This simplifies measurements, adjustments and, if necessary, component changes. If you have access to a scope, connect it to the output of the module and check whether Radio Frequency oscillations (RF) and excessive noise/hum are present. If you have complete audio instrumentation in your workshop, perform the usual gain, frequency response, noise, total harmonic distortion (THD), and intermodulation distortion (IM) measurements. Inputs should be shorted under DC measurements/adjustments.

Connect SGND to PGND at the output with jumper J2 or with a wire jumper. Connect the +INP to SGND, or install J1. Connect a mA meter in series with one of the supply lines. Turn on the supply voltage. If the current is >50mA, reduce it with P4 to 50mA. Connect a DVM across T1 and adjust the voltage drop with P2 to 3 Volt. Check the total supply current again and readjust it with P4 to 90 mA. Switch off the power supply, remove the mA meter, and connect the DVM to the output of the amplifier. Switch on the supply and adjust the output offset with P3 to less than 2 mV. Install Q9 and monitor the output offset, it should go down to less than 2 mV in a couple of minutes.

You can now remove the short from the +INP and -INP and if you have audio instrumentation, carry out the usual AC measurements.

Fig. 7 shows the stuffing guide, which is printed on the PCB.

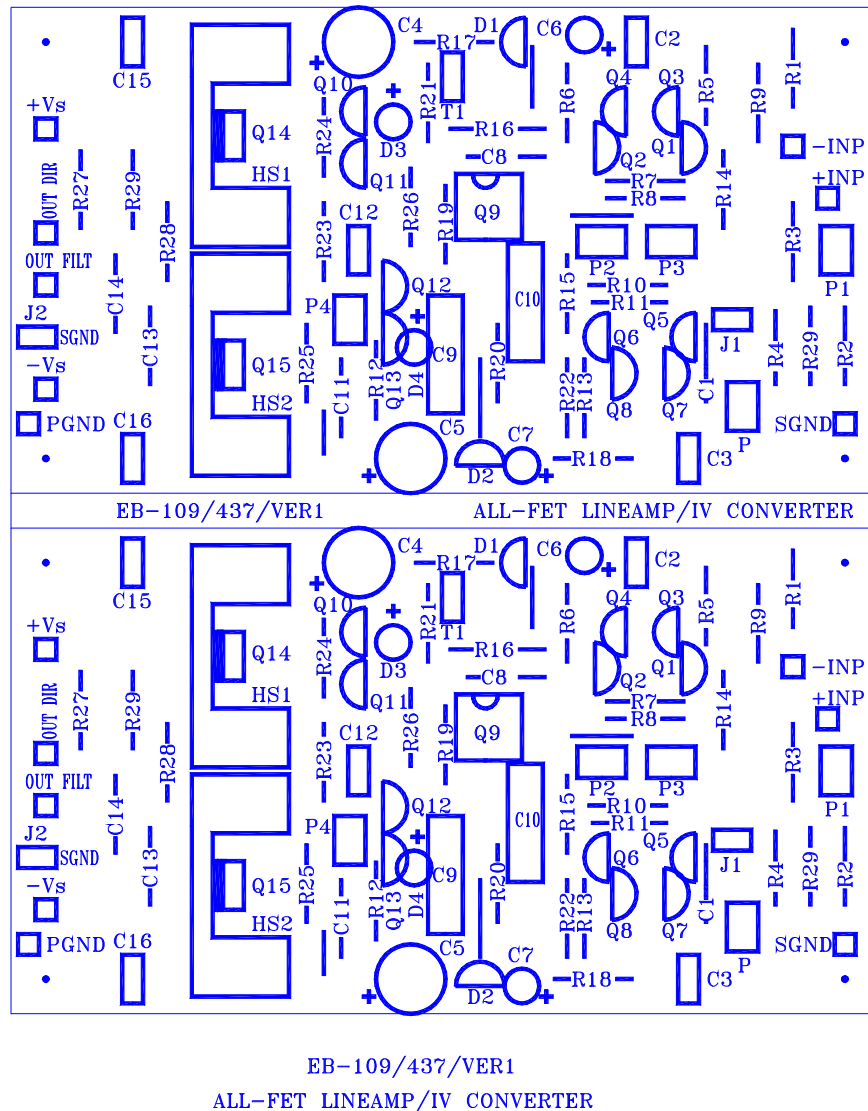

Fig. 7. Stuffing guide for EB-109/437.

References.

1. **Hagerman Technology.** <http://www.hagtech.com/pdf/hagdac.pdf>
HagDac DAC card custom modified for Borbely Audio
2. **K&K Audio.** <http://www.kandkaudio.com/digitalaudio.html>
RAKK DAC Mark III Digital-to-Analog Converter.
3. **Twisted Pear Audio.** <http://www.twistedpearaudio.com/digital/buffalo.aspx>
Buffalo II using the ES9018 DAC chip

The ALL-FET IV CONVERTER EB-109/437/VER1 and the ALL-FET super-shunt regulator EB-906/255 are the intellectual property of ERNO BORBELY/BORBELY AUDIO. Commercial use and duplication in any form is forbidden.